

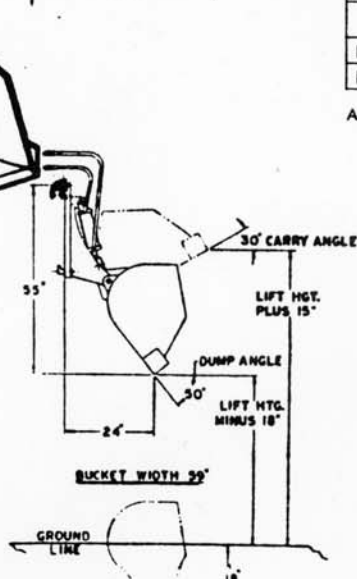

HYDRAULIC & MECHANICAL SCOOPS

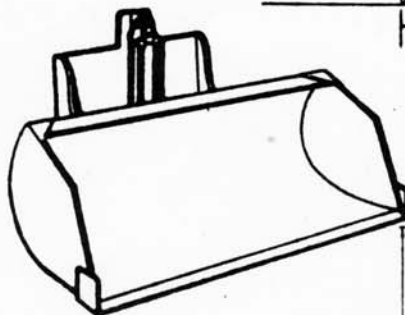
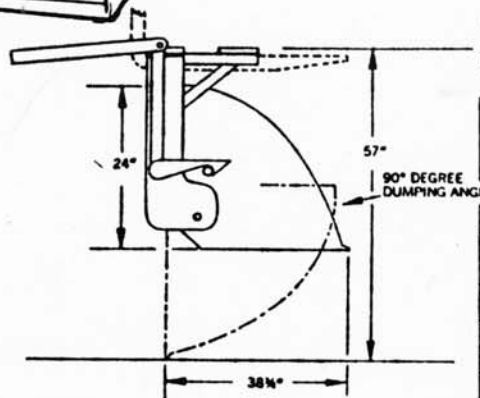
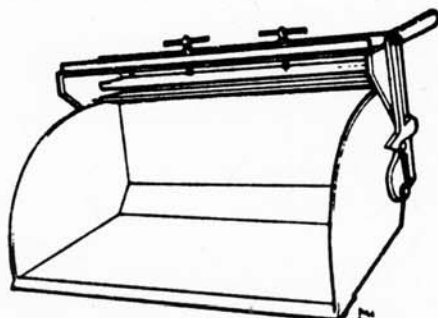
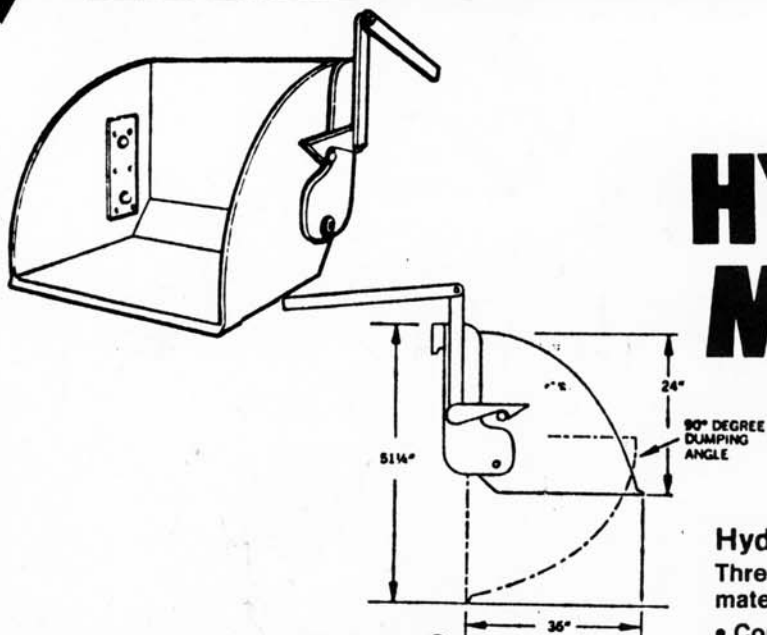

Hydraulic & Mechanical Scoops

Three versatile attachments for indoor or outdoor bulk material applications.

- **Complete control from driver's seat** — all aspects of scooping and dumping cycle done from safety of operator's seat.
- **Durable blade** — the bucket has a hardened steel blade to resist abrasion.
- **Mechanical or Hydraulic operation** — two mechanical scoops offer either carriage or fork mount options. Hydraulic scoop is mounted on the carriage.
- **Easy installation** — quick release kit is available for removal of scoop to free the lift truck for pallet operations.
- **Welded Hardened Steel Blade**

Scoop Specifications

Model No.	Max. Cap. (Lbs.)	Struck Cap. Cu. Ft.	Width (In.)	Depth (In.)	Height (In.)	Weight (Lbs.)
Mechanical — Carriage Mounted						
SB3824	2000	13	38	36	24	498
SB4824	2500	16	48	36	24	577
SB5824	3000	20	58	36	24	695
Mechanical — Fork Mounted						
FSB3824	2000	13	38	38 1/2	24	674
FSB4824	2500	16	48	38 1/2	24	758
FSB5824	3000	20	58	38 1/2	24	875
Hydraulic — Carriage Mounted A.						
BH5905	3000	13	59	24 1/2	21 1/2	610
BH6605	4000	15	66	24 1/2	21 1/2	860

A. 30° Back Tilt, 50° Forward Tilt



201 W. Oklahoma Ave.
(580) 227-3711

Fairview, OK 73737
FAX 580-227-2165